

PLEXIGLAS HEATSTOP® SDP 16/980 (/1200) - 32

Product Description

Technical Information

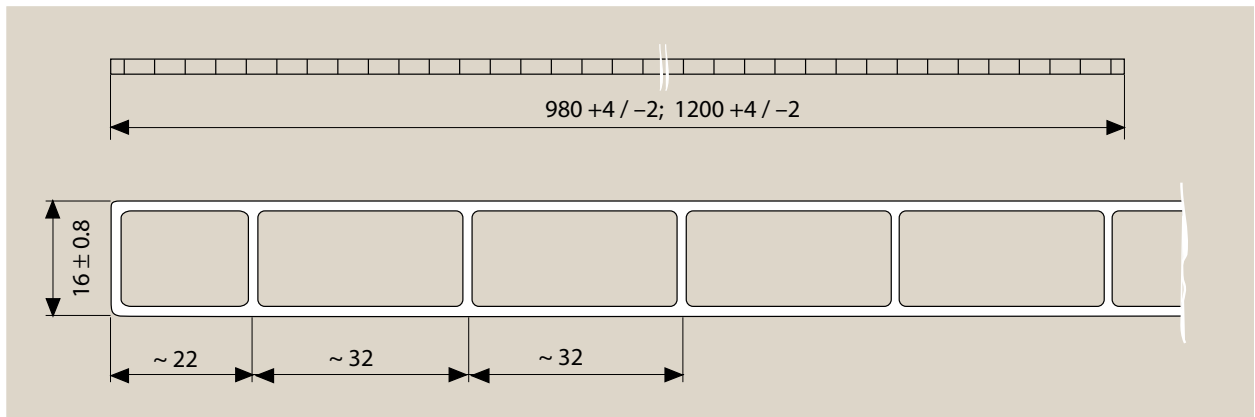

Section of PLEXIGLAS HEATSTOP® SDP 16 (Dimensions in mm)

Product and Benefits

PLEXIGLAS HEATSTOP® SDP 16 is an **IR-(infrared) reflecting, heat-insulating** and highly weather-resistant double-skin sheet made of **impact-modified** acrylic (poly-methyl methacrylate, PMMA).

In this double-skin sheet, the HEATSTOP protection is not applied to one side as a surface coating, but is uniformly integrated into the sheet substrate.

The PLEXIGLAS HEATSTOP® SDP 16 double-skin sheet offers the user major advantages:

- **impact strength** during transport, handling and installation,
- **hail resistance** with a guaranteed long-term energy value of 1 joule,
- it **reduces** heat buildup in rooms due to sunlight by almost **50%** and provides particularly **uniform daylighting**.

The **HEATSTOP** protection gives the sheets an attractive, reddish-purple surface gloss. Seen from below, the sheets appear pleasantly cool, as befits their function. This coloring has an iridescent effect. The color impression may change depending on viewing angle and lighting conditions.

NO DROP – Coating

When installed with the water-dispersing **NO DROP*** coating on one side facing upwards/outwards, this offers the advantages that the NO DROP coating ensures a better cleaning effect and more rapid drying in wet weather.

When installed facing downwards/inwards, any condensation flows off as a continuous film, preventing uncontrolled dripping and letting more light into the glazed area.

The NO DROP coating is covered by a protective layer applied during manufacture. This is washed off by rainwater or condensation, thus activating the NO DROP coating. The protective layer can also be removed with water and a sponge or by using a hose.



The sheet is completely protected against UV radiation by the „Naturally UV-Stable Technology.“

*) Europ. Patent 149 182

Technical Data (Typical Values)

Available lengths	2,000 to 7,000 mm	
Light transmittance \bar{T}_{D65}	White WR004	ca. 50 %
Total energy transmission g	NO DROP:	ca. 40 %
Selectivity factor	(UV-absorbing)	1.25
U-value	2.5 W/m ² K (Test report 13-901399/P1/Fi, FMPA Stuttgart)	
Coefficient of linear thermal expansion	0.09 mm/m °C	
Possible expansion due to heat and moisture	c. 6 mm/m	
Max. permanent service temperature without load	70 °C	
Weighted sound reduction index (estimated)	24 dB	
Minimum permissible cold-curving radius	2,400 mm	

Fire Behavior

- PLEXIGLAS® is rated in Euroclass E to DIN EN 13501 with regard to fire behavior.
- PLEXIGLAS® burns almost without smoke according to DIN 4102 and is easy to extinguish.
- The smoke gases produced by PLEXIGLAS® are not acutely toxic according to DIN 53436 and are non-corrosive according to DIN VDE 0482-267.
- Roof surfaces glazed with PLEXIGLAS® open up by melting in the event of fire and allow smoke and heat to escape.

Guarantee

10-year guarantee for the light transmission, hail resistance, rigidity and strength (www.plexiglas.net).

Loadbearing Capacity

As **flat** glazing supported on all sides, the multi-skin sheet with the width of 980 mm requires **no additional cross members** for the load of 750 N/m²; the sheet width 1,200 mm requires **cross members spaced at 4.90 m**.

Cold-Curving

For roof glazing in the form of **barrel vaults**, the multi-skin sheets are usually **cold**-curved over the regularly shaped circular (metal) hoops.

A high loadbearing capacity is obtained at small radii. The **minimum cold-curving radius** for PLEXIGLAS HEATSTOP® SDP 16 is **2,400 mm (= 150 x thickness)**.

When spacing the hoops, the expansion and the rebate or clamping depth of at least 15 mm must be borne in mind.

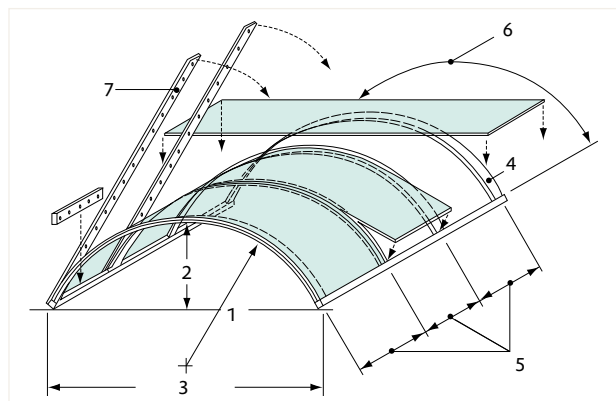

1 = Radius

2 = Pitch

3 = Span

4 = Hoop

5 = Hoop spacing

6 = Arc length

7 = Clamping bar

® = registered trademark

PLEXIGLAS and PLEXIGLAS HEATSTOP are registered trademarks of Evonik Röhm GmbH, Darmstadt, Germany.

Certified to DIN EN ISO 9001 (quality) and DIN EN ISO 14001 (environment)

This information and all further technical advice is based on our present knowledge and experience. However, it implies no liability or other legal responsibility on our part, also with regard to existing third party intellectual property rights, especially patent rights. In particular, no warranty, whether express or implied, or guarantee of product properties in the legal sense is intended or implied. We reserve the right to make any changes according to technological progress or further developments. The customer is not released from the obligation to conduct careful inspection and testing of incoming goods. Performance of the product described herein should be verified by testing, which should be carried out only by qualified experts in the sole responsibility of a customer. Reference to trade names used by other companies is neither a recommendation, nor does it imply that similar products could not be used.

Ref-No. 234-20 March 2008
xx/0308/09562 (en)

Business Unit Performance Polymers

Evonik Röhm GmbH Kirschenallee 64293 Darmstadt, Germany
info@plexiglas.net www.plexiglas.net www.evonik.com



EVONIK
INDUSTRIES